











Non-Backlash CNC ROTARY TABLE

機械式樣表 Specification

機型 Code No.		AT320R AT320L	AT320S	AT400R AT400L	
工作盤直徑 Table diameter	ø mm	320	400	400	
中心高度 Center height	mm	210	210	255	
中心孔徑/貫穿孔徑 Spindle hole	ø mm	130H7/90	130H7/90	150H7/120	
盤面 T 型溝尺寸 T slot width	mm	14H7	14H7	14H7	
基準定位鍵 Guide block width	mm	18h7	18h7	18h7	
使用馬達 Motor	FANUC	α	α 12iF	α 12iF	
	MITSUBISHI	β	β 12is/β 22is	β 22is	
	SIEMENS		HG204S	HG204S	
			1FK7083/1FK2208	1FK7083/1FK2208	
總減速比 Gear ratio		90	90	120	
工作盤最高迴轉速 Max. rotation speed (註 Note)	rpm	33.3	33.3	25	
最小設定單位 Min. increment		0.001°	0.001°	0.001°	
R/G額定動定格 Basic dynamic load rating	kgf·m	98.9	98.9	195.3	
鎖緊壓力 Clamp system (空 P: Pneumatic / 油 H: Hydraulic)	kg/cm ²	(油 H) 35	(油 H) 35	(油 H) 35	
	鎖緊扭力 Output torque at brake	kg·m	250	250	500
	N·m	1470	1470	2744	
分割精度 Indexing accuracy	sec	20	20	15	
重覆精度 Repeatability	sec	4	4	4	
製品質量 Weight	kg	200	200	250	
容許承重 Allowable work weight	 (有尾座時容許承重) (Allowable work weight with tailstock)	kg	200 (400)	200 (400)	250 (500)
		kg	400	400	500
當夾鎖時其容許負載 Allowable load (When table clamped)		kgf	2000	2000	4000
		FxL Kgf·m	260	260	280
		FxL kgf·m	400	400	500
容許慣性 Allowable work inertia		kg·m ²	7.5	7.5	10
不含刹車時間 Cycle time	 90°	sec	0.57	0.57	0.76
	 180°	sec	1.02	1.02	1.36

註: 馬達轉速3000rpm Note: Motor speed 3000 rpm.

機械寸法圖 Outline dimensions

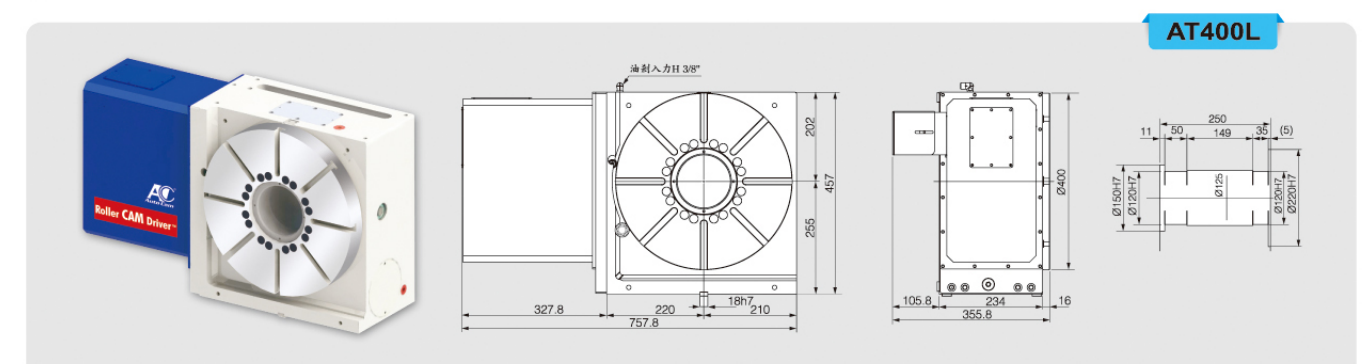
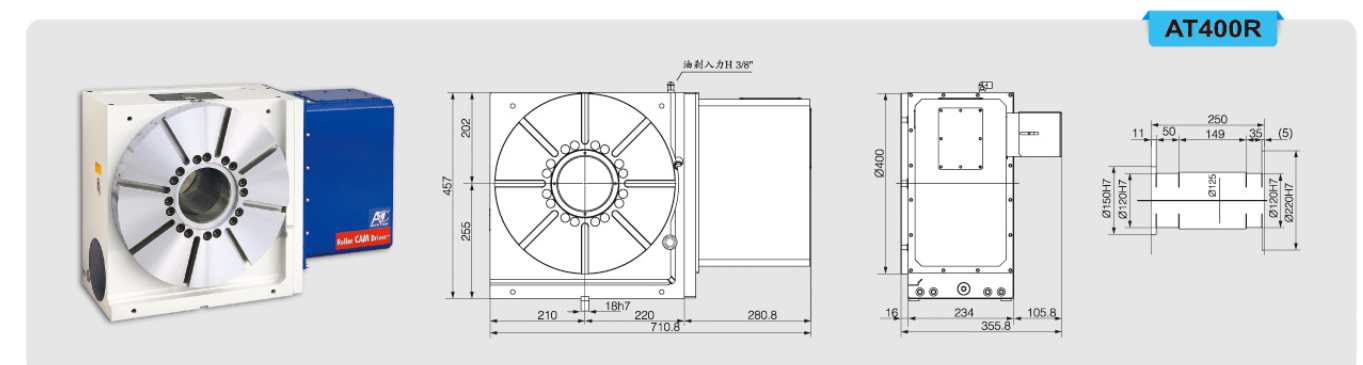
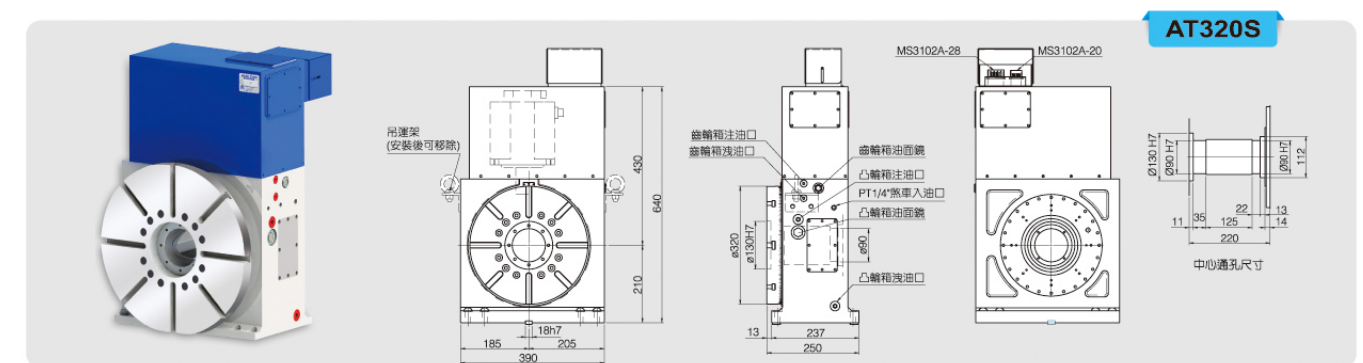
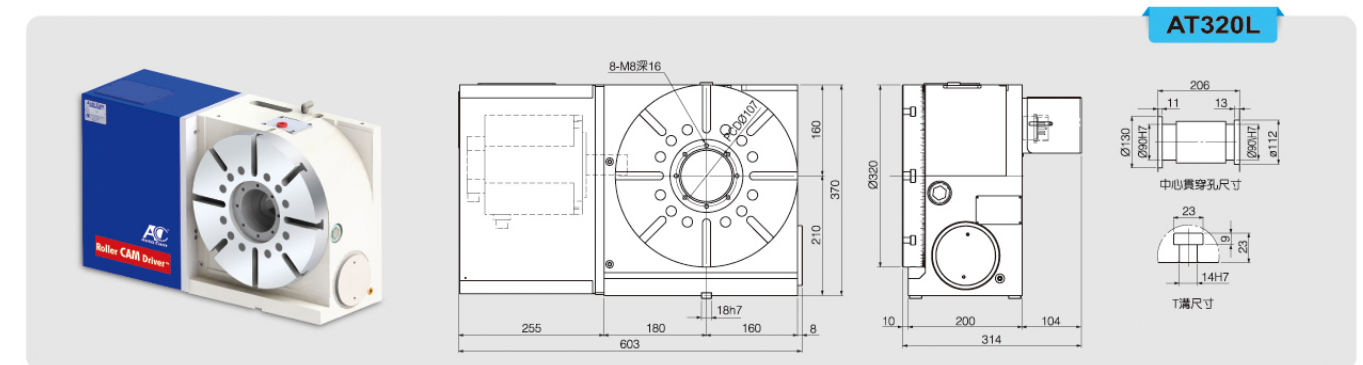
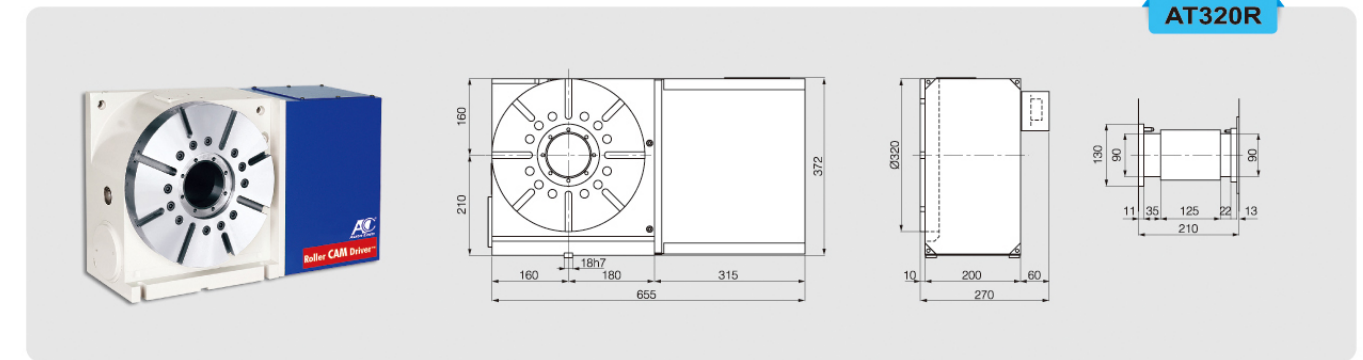

Non-Backlash CNC ROTARY TABLE

機械式樣表 Specification

機型 Code No.		AT500R	AT630R	AT800R	
工作盤直徑 Table diameter	ø mm	500	630	800	
中心高度 Center height	mm	320	400	530	
中心孔徑/貫穿孔徑 Spindle hole	ø mm	200H7/140	60H7/60	400H7/350	
盤面 T 型溝尺寸 T slot width	mm	18H7	18H7	18H7	
基準定位鍵 Guide block width	mm	18h7	18h7	22h7	
使用馬達 Motor	FANUC	α	α12iF/α22iF	α22iF	
		β	β22is	β22is	
	MITSUBISHI		HG204S/HG354S	HG354S	
	SIEMENS		1FK7083/1FK7101/1FK2208 /1FK2210	1FK7083/1FK7101/1FK2208 /1FK2210	
總減速比 Gear ratio		90	150	120	
工作盤最高迴轉速 Max. rotation speed (註 Note)	rpm	33.3	20	25	
最小設定單位 Min. increment		0.001°	0.001°	0.001°	
R/G額定動定格 Basic dynamic load rating	kgf·m	407.8	474.8	1330.8	
鎖緊壓力 Clamp system (空 P: Pneumatic / 油 H: Hydraulic)	kg/cm ²	(油 H) 35	(油 H) 35	(油 H) 35	
	kg·m	700	750	1200	
鎖緊扭力 Output torque at brake	N·m	3920	5390	6860	
	sec	15	20	15	
分割精度 Indexing accuracy	sec	4	4	4	
重覆精度 Repeatability	kg	450	870	1400	
容許承重 Allowable work weight	(有尾座時容許承重) (Allowable work weight with tailstock)	kg	400(800)	500(1000)	750(1500)
	kg		800	1000	1500
當夾鎖時其容許負載 Allowable load (When table clamped)	kgf		5000	1000	6000
	FxL		400	300	700
	kgf·m		700	850	1000
	FxL				
容許慣性 Allowable work inertia	kg·m ²		20	50	120
不含刹車時間 Cycle time	90°	sec	0.76	0.91	1.14
	180°	sec	1.36	1.66	2.04

註: 馬達轉速3000rpm Note: Motor speed 3000 rpm.

機械寸法圖 Outline dimensions

